

## New Exploration/Exploitation Improvements of GWO for Robust Control of a Nonlinear Inverted Pendulum

Soumia Mohammed Djaouti<sup>[1, A]</sup>, Mohamed Fayçal Khelfi<sup>[2, B]</sup>, Mimoun Malki<sup>[1, C]</sup>, Mohammed Salem<sup>[3, D]</sup>

<sup>[1]</sup> LabRI-Sidi Bel Abbes Laboratory, Ecole Supérieure en Informatique de Sidi Bel-Abbes (ESI-Sidi Bel Abbes), Algeria

<sup>[2]</sup> RIIR Laboratory, University of Oran1 Ahmed Ben Bella, Higher School of Electrical and Energetic Engineering of Oran, Oran, Algeria

<sup>[3]</sup> University of Mascara, Mascara, Algeria

<sup>[A]</sup> s.mohammeddjaouti@esi-sba.dz, <sup>[B]</sup> mf\_khelfi@yahoo.fr, <sup>[C]</sup> m.malki@esi-sba.dz, <sup>[D]</sup> salem@univ-mascara.dz

**Abstract** Tuning a nonlinear inverted pendulum is a complex and uncertain optimization problem. In this paper, we develop two new GWO variants by introducing a DLH (Dimension Learning-based Hunting) module and new formulas to enhance the exploitation/exploration ratio aiming to avoid local minima. A statistical analysis is carried out to compare the two proposed approaches with five GWO variants. After that, they are used to tune a PID and FSMC controller. The obtained results are promising even when compared to other approaches.

**Keywords:** GWO algorithm, DLH strategy, PID, Sliding mode control, Fuzzy logic control, Inverted pendulum.

### 1 Introduction

Evolutionary algorithms are used to resolve engineering problems such as control of systems. In control theory, the inverted pendulum has become a hot topic as a typical nonlinear and unstable system. It is a simple pendulum whose mass is located in the air. The system presents an unstable equilibrium in a vertical position. This position is maintained by the control of a movable cart. To achieve that, a variety of methods for inverted pendulum control are presented in the literature to control the cart position, to stabilize the pole, or for both of them. Many controllers are proposed in literature to stabilize the inverted pendulum among them the PID and the sliding mode controllers.

Today, PID controller is the most typical and popular controller widely used in industrial control structure because of its robustness, simplicity and ease of tuning its parameters. It uses three parameters which are the proportional (P), integral (I) and differential (D) factors to convert error signals into input signals. Best tuning of these parameters will eliminate steady state error which increase stability of the process and boost the dynamic response of a system.

Sliding mode control (SMC) is easy to tune and implement special nonlinear control featuring remarkable properties of accuracy and robustness. SMC has proved its effectiveness through several theoretical studies. The advantages provided by such control are quick response, insensitive to parameters variation, and robustness against disturbances and uncertainties of the model. However, the appearance of the chattering phenomena, caused by the discontinuous control, is a severe problem when the state of the system is close to the sliding surface. Fuzzy sliding mode controller (FSMC) is a sliding mode with a fuzzy control (FLC) part. FLC can alleviate some of the SMC's problems by eliminating high frequencies and substantially decreasing the noise sensitivity. Both the abovementioned controllers' parameters are tuned by trial/error which is time consuming and does not guarantee good performance.

The drawback of the former could be solved using an optimization technique like the grey wolf optimizer (GWO) to tune the parameters of both PID and FSMC controller. Grey wolf optimizer is a new nature-inspired meta-heuristic inspired by the social behaviour and hunting mechanism of grey wolves [1]. The population is divided into four hierarchical groups: alpha, beta, delta and omega. Alphas are the leaders of the pack and are responsible of all the decisions so are considered as the optimal solution in the optimization process while the others execute the decisions of the upper levels in the hierarchy.

This algorithm is simple to implement and powerful to solve different optimization problems with less computational efforts and time complexity [2], however GWO has two major drawbacks: the first one is the built-in exploration/exploitation ratio where it uses a constant 50/50 ratio between the search mechanisms while other

ISSN: 1137-3601 (print), 1988-3064 (on-line)

©IBERAMIA and the authors

optimization algorithms try to look for a decreasing ratio to fasten the search process. Indeed, in the first iterations, the algorithm needs more exploration to avoid local minima and explore the different parts of the search space while in the last iterations; it had to focus on a special location of the space to enhance the found solution which means more exploitation than exploration.

The second drawback is the dependency between the wolves' categories where the positions of low levels groups are dependent to the alpha wolves' location which lead to the known local minima.

Therefore, many strategies have been proposed by introducing new concepts and approaches to improve the GWO and overcome these two issues among them: Enhanced Grey Wolf Optimization (EGWO) [3], modified Grey Wolf Optimization (mGWO) [4], Augmented Grey Wolf Optimization (AGWO) [5] and Improved Grey Wolf Optimization (IGWO) [6]. All of these variants update the original algorithm by introducing new formulas to enhance the exploration/ exploitation ratio (mGWO, EGWO and AGWO) or /and decrease the dependency to alpha wolves (IGWO, EGWO).

In this paper, we present a new GWO variants which combines the DLH strategy [7] with a modified GWO where two enhancements are proposed: the first one is a new control parameter a formula to improve the exploration/exploitation ratio and the second one is a new movement strategy depending on the first four wolves so to decrease the dependency of the wolves movement which are dependent on the alpha wolves in the original algorithm.

First of all, the proposed GWO variants are validated using statistical analysis to compare them with five well known GWO variants (AGWO, EGWO, GWO, IGWO and mGWO) [1][3][4][5][6] via Wilcoxon and Friedman tests then they are used to find the optimal set of parameters for PID and FSMC controllers to achieve a precise tracking performance for an inverted pendulum in the presence of external disturbances. Indeed, tuning of these two controllers is a complex, uncertain and noisy optimization problem which makes it a good test bed problem for the proposed algorithms.

The remainder of this paper is organized as follows: the control of a nonlinear inverted pendulum is presented in section 2. Section 3 describes the Grey Wolf optimization process and highlights the enhancements involved in it. Statistical analysis is provided to test GWO variants in section 4. Simulation results and discussion for GWO based optimization variants of FSMC and PID controller for an Inverted Pendulum are given in section 5. Section 6 concludes this work.

## 2 Control of a nonlinear Inverted pendulum

### 2.1 Modelling an Inverted pendulum

The classical inverted pendulum shown in figure 1 is composed of a pendulum attached to a cart [8]. It consists of a nonlinear second-order system given by equation (1):

$$\dot{\theta} = f(x) + g(x). u(t) + d(t) \tag{1}$$

Where  $x(t) = [\theta \ \dot{\theta}]$  is the state vector,  $d(t)$  is the external disturbance and  $u(t)$  is the control vector [9].  $f$  and  $g$  are two nonlinear functions describing the dynamical system.

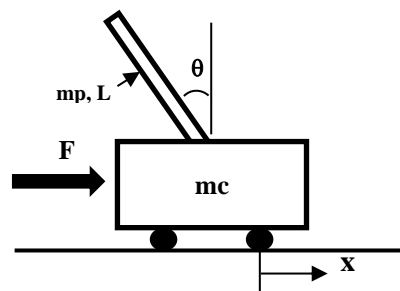

Figure 1. An inverted pendulum.

By applying a horizontal force  $F$ , the cart moves only in the horizontal direction and provokes a deviation of the pole of  $\theta$  radians.

$$\dot{\theta} = \frac{gr \sin(\dot{\theta}) - mp L \dot{\theta}^2 \cos(\theta) \sin(\theta) / (mc + mp)}{L (4/3 - mp \cos^2(\theta) / (mc + mp))} + \frac{\cos(\theta) / (mc + mp)}{L (4/3 - mp \cos^2(\theta) / (mc + mp))} u(t) + d(t) \tag{2}$$

Where  $\theta$  and  $\dot{\theta}$  are respectively the angular position and the velocity of the pole,  $mc$  and  $mp$  are the mass of the cart and the pendulum respectively.  $L$  is the half-length of the pole and  $gr$  is the gravity [9].

The control of the nonlinear inverted pendulum is a real problem which consists in maintaining the unstable pole in the vertical position  $\theta = 0$  by controlling the position of the movable cart [10]. To achieve that, we consider two controllers: the PID controller and Fuzzy Sliding Mode (FSMC) controller.

## 2.2 Proportional Integral Derivative (PID) controller

The PID controller consist of three parameters: proportional  $k_p$ , integral  $k_i$  and derivative  $k_d$  gains (see figure 2). The control law is given by:

$$u(t) = k_p e(t) + k_d \dot{e}(t) + k_i \int e(t) dt \quad (3)$$

where  $e(t)$  is the control error between the Inverted Pendulum output  $\theta(t)$  and the desired output  $\theta_d(t)$  :

$$e(t) = \theta_d(t) - \theta(t) \quad (4)$$

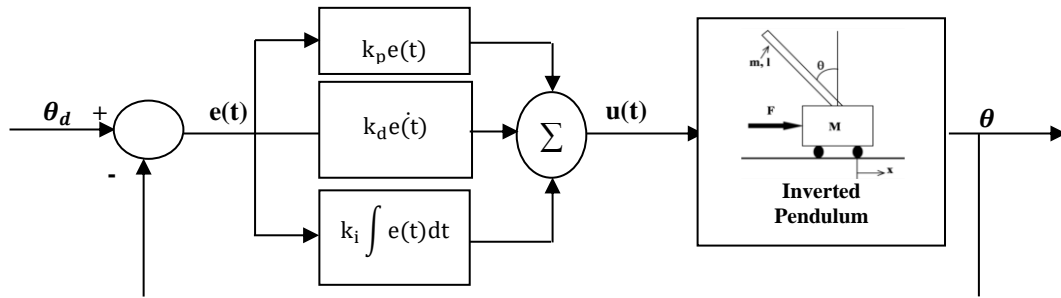

Figure 2. Proportional, Integral and Derivative controller structure.

## 2.3 Fuzzy Sliding Mode Control

A Fuzzy Sliding Mode controller consists of a Sliding Mode controller part (SMC) and a Fuzzy Logic controller part (FLC) (see figure3). In the SMC part, two components exist: a discontinuous component to drive the system states to the sliding surface and a continuous component which is responsible of keeping the system on the surface to force the error variables to the origin [11]:

$$u(t) = \frac{1}{g(x)} [-f(x) + \ddot{x}_d(t) - \lambda \dot{x}(t) + \lambda \dot{x}_d(t) - d(t)] - k \cdot \text{sat}(s) \quad (5)$$

Where  $f$  and  $g$  are two nonlinear functions describing the system,  $\lambda$  is the slope,  $\text{sat}$  is a saturation function and  $k$  is a positive switching gain [12].

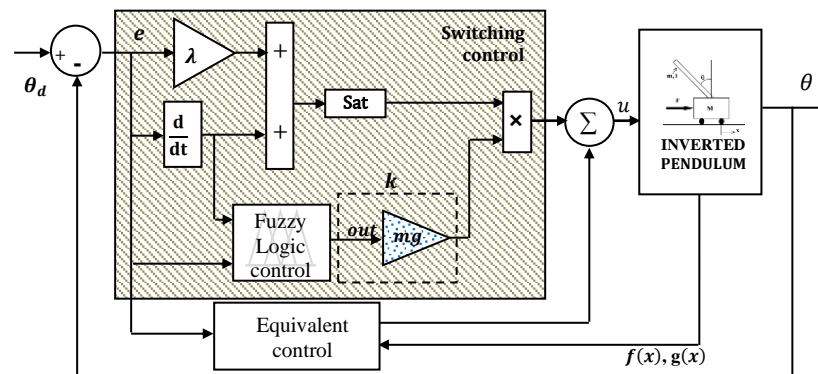

Figure 3. Fuzzy sliding mode controller FSMC

Adjusting the parameters of this controller could ensure its robustness and avoid the chattering phenomenon. These parameters are: the slope  $\lambda$ , the gain  $mg$  used to calculate the switching gain  $k$  (see in figure 3) and the membership functions and the indices of the fuzzy rules to be selected from the IF-THEN rules base illustrated in table 1. The error  $e$  and its rate of change  $\dot{e}$  are the inputs to the fuzzy inference system (FIS). The fuzzy subsets of inputs/output variables are expressed as follows: Negative small (Ns), Zero (Z), and positive small (Ps) for error  $e$ . Negative small (Nsp), zero (Zp), and positive small (Psp) for the derivative of error  $\dot{e}$ . Small (S), Middle (M), and Big (B) for the fuzzy output.

Table 1: Fuzzy rules table.

e \ e	Ns	Z	Ps
Nsp	B (1)	M (2)	B (3)
Zp	M (4)	S (5)	M (6)
Psp	B (7)	M (8)	B (9)

Thus, each membership function is defined by five parameters where a and e are respectively the upper and lower extremities of the fuzzy variable as described in figure 4.

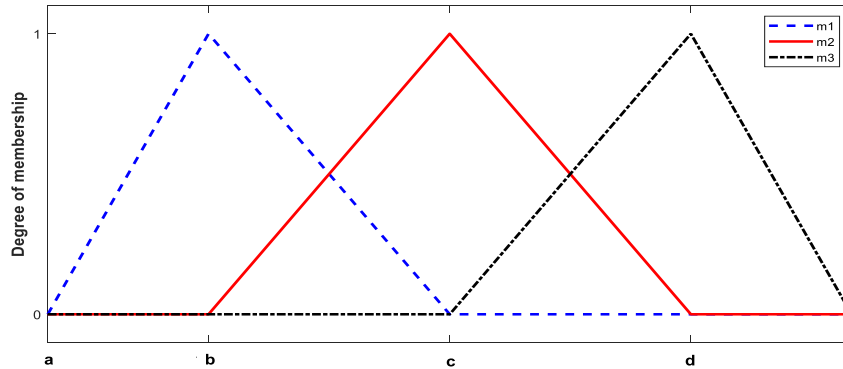

Figure 4. The membership functions coding of a variable

The parameters of both PID and FSMC controller are usually tuned by trial-error method which is time consuming and lead to a divergent controller. In this paper, we propose to enhance the GWO algorithms to optimize these two controllers.

### 3 Grey Wolf Optimizer (GWO)

The GWO is a new meta-heuristic that mimics the social behaviour, leadership hierarchy and hunting of grey wolves. Generally, grey wolves prefer to live in a pack which consists of four types of agents: alpha ( $\alpha$ ), beta ( $\beta$ ), delta wolf ( $\delta$ ) and omega ( $\omega$ ), and follow a three steps process when hunting: encircling, hunting, then attacking the prey. The hunting (optimization) is guided by the three first wolves: alpha, beta and delta representing the first, second and the third best solutions. The omega wolves are iteratively improved according to the three first wolves [1].

During iterations, each wolf (i) has a position in the  $t^{th}$  iteration given as a vector of real values  $X_i(t) = \{X_{i1}, X_{i2}, \dots, X_{id}\}$ , where d is the dimension of the problem.

The population of wolves is arranged in a matrix of dimension  $(N \times d)$  then  $X_i(t)$  are evaluated by a fitness function  $f(X_i(t))$ .

Firstly, the grey wolves encircle the prey according to the mathematical model given by the following equation:  

$$D = |C \cdot X_p - X| \tag{6}$$

Where  $X_p$  and  $X$  indicate respectively the positions of the prey and the current wolf. D is the distance between them. The first wolves update their positions by:

$$X(t) = X_p(t) - A \cdot D \tag{7}$$

Where A and C are two vectors furnishing direction for the activities to ensure that all wolves do not always go in the same direction. They are calculated by the following equations:

$$A = 2a \cdot r_1 - a \tag{8}$$

$$C = 2 \cdot r_2 \tag{9}$$

$$a = 2 \left( 1 - \frac{t}{T} \right) \tag{10}$$

where  $r_1, r_2$  are two random vectors and a is a vector which linearly decreases from 2 to 0 over the course of iterations. t is the current iteration and T is the maximum number of iterations [1].

The position of each omega wolf X is updated by the leaders' positions  $X_1, X_2$  and  $X_3$  by equation:

$$X(t+1) = \frac{X_1 + X_2 + X_3}{3} \tag{11}$$

Where

$$X_1 = X_\alpha - A_1 \cdot (D_\alpha), \quad X_2 = X_\beta - A_2 \cdot (D_\beta), \quad X_3 = X_\delta - A_3 \cdot (D_\delta) \tag{12}$$

$$D_\alpha = |C_1 \cdot X_\alpha - X|, \quad D_\beta = |C_2 \cdot X_\beta - X|, \quad D_\delta = |C_3 \cdot X_\delta - X| \tag{13}$$

Omega wolves cannot efficiently explore the search space because they always follow the leaders. This lack of exploration increases the possibility of local optima trapping [6].

A number of GWO variants have been developed to avoid this problem and accelerate convergence rate by enhancing the ratio between exploitation and exploration. In the next section, an enhanced variant is proposed to improve the original GWO.

### 3.1 The proposed algorithm

In this section, a hybridization of the GWO with the dimension learning-based hunting (DLH) strategy is proposed. The DLH is a new movement strategy inherited from the individual hunting behaviour of wolves in nature. The strategy can balance the global and local search and maintain population diversity by sharing information among search agents. This diversity is important to improve the convergence speed and accuracy of the algorithm [13].

The proposal is inspired by the work of [6] with two new enhancements in the GWO phase. The main flowchart of this proposal is in figure 5:

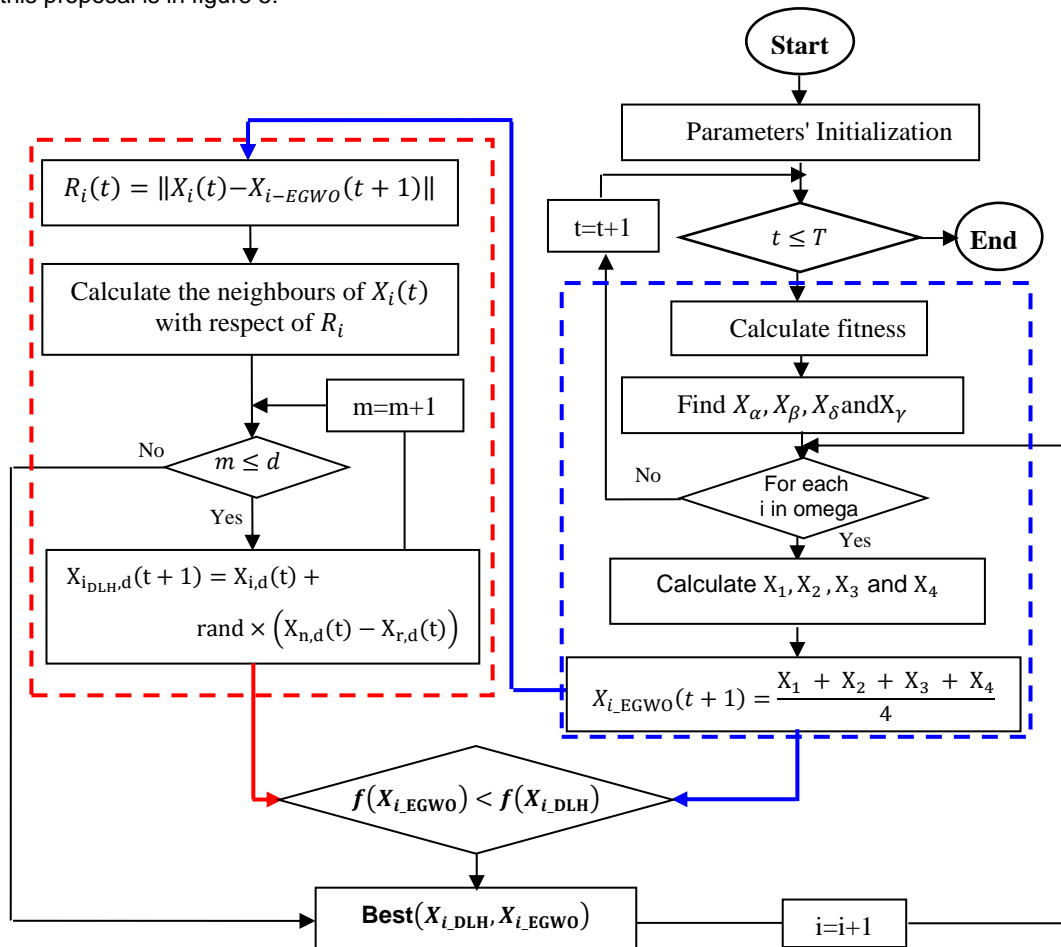

Figure 5. The flowchart of the proposed algorithm

#### 3.1.1 Initializing phase

A population of  $N$  wolves is initialized randomly within a search space in a range  $[l_j, u_j]$ :

$$X_{ij} = l_j + \text{rand}_j[0,1] \times (u_j - l_j), i \in [1, N], j \in [1, d] \quad (14)$$

The fitness value of  $X_i(t)$  is computed by the cost function,  $f(X_i(t))$ .

The new positions of the wolves in an iteration  $t$  are computed through three phases:

### 3.1.2 Movement Phase

In the flowchart of figure 1, two major changes are proposed into the GWO part of the optimization algorithm:

- First, we have proposed new formulas to compute the decreasing parameter (a) which is needed to get the leaders' positions:

$$a = 2 - \left( \cos(\text{rand}(\ )) \times \frac{t}{T} \right) \tag{15a}$$

$$a = 2 \left( 1 - \frac{t^2}{T^2} \right) \tag{15b}$$

- Second, we consider that the leaders of the pack are the best four wolves:  $X_\alpha$ ,  $X_\beta$ ,  $X_\delta$  and  $X_\gamma$ . The positions of the leaders are computed using equation (12) but with new values of the parameter a given in equation (15). The position of the fourth leader is calculated using equation:

$$X_4 = X_\gamma - A_4 \cdot (D_\gamma), \quad D_\gamma = |C_4 \cdot X_\gamma - X| \tag{16}$$

where  $D_\gamma$  is the distance between  $\gamma$  wolf to each of the remaining wolves.

The omega wolves update their positions according to the four leaders by:

$$X_{i\_EGWO}(t + 1) = \frac{X_1 + X_2 + X_3 + X_4}{4} \tag{17}$$

### 3.1.3 DLH phase

In the DLH phase, the neighbourhood of  $X_i(t)$  is calculated using the radius between the current location of  $X_i(t)$  and  $X_{i\_EGWO}(t + 1)$  :

$$N_i(t) = \{X_j(t) \mid D_i(X_i(t), X_j(t)) \leq \|X_i(t) - X_{i\_EGWO}(t + 1)\|, X_j(t) \in \text{pop}\} \tag{18}$$

Where  $D_i$  illustrates Euclidean distance between  $X_i(t)$  and  $X_j(t)$ .

To calculate the  $d^{\text{th}}$  dimension of  $X_{i\_DLH,d}(t + 1)$  candidate, a multi neighbours learning is carried out by equation (19) using the  $d^{\text{th}}$  dimension of a random neighbor  $X_{n,d}(t)$  selected from  $N_i(t)$ , and a random wolf  $X_{r,d}(t)$  from Pop:

$$X_{i\_DLH,d}(t + 1) = X_{i,d}(t) + \text{rand} \times (X_{n,d}(t) - X_{r,d}(t)) \tag{19}$$

### 3.1.4 Selecting and updating phase

In this phase, the fitness values of  $X_{i\_EGWO}(t + 1)$  and  $X_{i\_DLH}(t + 1)$  are compared and the best of them indicate the next position of  $X_i(t)$  [13].

$$X_i(t + 1) = \begin{cases} X_{i\_EGWO}(t + 1), & \text{if } f(X_{i\_EGWO}) < f(X_{i\_DLH}) \\ X_{i\_DLH}(t + 1) & \text{otherwise} \end{cases} \tag{20}$$

In the remainder of the paper, we will call COGWO the algorithm that used the cosine version given in equation (15a) and EXGWO the one using the exponential version given in Equation (15b).

In order to evaluate the performance of the considered proposals, we will achieve a comparative analysis in the next section using statistical tests.

## 4 Statistical analysis of the GWO variants

Statistical tests are techniques employed to extract deductions about one or more populations from given samples. In order to do that, two hypotheses are defined: the null hypothesis and the alternative hypothesis. The null hypothesis is a report of no difference between algorithms, whereas the alternative hypothesis indicates the presence of significant differences between them. When applying a statistical test to reject a hypothesis, a predefined threshold or a significance level  $\alpha$  is used to determine at which level the hypothesis may be rejected. If the obtained value is less than a predefined threshold alpha, the null hypothesis is accepted else it is rejected and then, we will accept the alternative hypothesis [14].

To evaluate the performance of enhanced GWO variants considered in this paper, two alternative tests are applied: parametric and nonparametric tests. Parametric tests are the robust test into the statistical tests but their use is conditioned by three criteria: normality, data independence and heteroscedasticity [15]. If these conditions are not checked, nonparametric tests are used despite they are less powerful.

Twenty-three typical benchmark functions, listed in [1], are selected to carry out simulation experiments for the proposed GWO variants with the original Grey Wolf Optimizer (GWO), Augmented GWO (AGWO), Enhanced GWO (EGWO), Improved GWO(IGWO) and Modified GWO (mGWO). These objective functions are used to test the capability of algorithms to cover different types of problems such as the exploitation/exploration capabilities and their ability for various optima [1].

Each algorithm is executed, for each benchmark function, for twenty independent runs with a population size of 50 search agents and 100000xd evaluation where d is the dimension of the problem. The mean errors calculated from the best values obtained from all the performed runs are shown in table 2.

Table 2: The mean errors of the concerned algorithms.

Functions	AGWO	EGWO	GWO	IGWO	mGWO	COGWO	EXGWO
F1	1.07e+03	865.9188	587.6836	407.1184	4.76e+02	4.62e+02	4.90e+02
F2	3.53e+09	1.72e+07	2.59e+06	8.46e+08	3.42e+09	1.16e+07	1.79e+07
F3	6.69e+03	1.71e+03	2.35e+03	2.71e+03	2.16e+03	2.96e+03	8.39e+02
F4	13.2218	115.1817	2.1779	2.5532	6.22e-01	3.50e+00	1.41e+01
F5	3.18e+06	3.30e+11	1.31e+06	1.08e+06	1.22e+06	9.53e+05	1.01e+06
F6	1.19e+03	1.30e+06	502.0940	458.8486	5.62e+02	4.75e+02	7.04e+02
F7	1.6839	0.7851	6.43e-01	4.21e-01	6.99e-01	4.32e-01	3.49e-01
F8	-3.50e+03	-6.66e+03	-4.72e+03	-5.58e+03	-3.58e+03	-6.23e+03	-8.97e+03
F9	55.4545	166.7398	2.04e+01	1.40e+02	2.44e+01	1.69e+02	7.72e+01
F10	1.3083	1.0880	0.6716	6.33e-01	7.99e-01	6.12e-01	6.09e+00
F11	12.8813	6.6765	4.80e+00	3.77e+00	6.24e+00	4.35e+00	6.44e+00
F12	1.17e+07	4.24e+06	5.85e+06	2.04e+06	3.24e+06	2.11e+06	2.01e+06
F13	1.80e+07	3.22e+06	3.96e+06	4.38e+06	5.73e+06	3.10e+06	2.45e+06
F14	3.1019	3.7986	3.0315	1.12e+00	3.16e+00	1.21e+00	1.11e+00
F15	9.15e-04	0.0011	8.93e-04	7.32e-04	7.51e-04	8.84e-04	2.20e-03
F16	-1.0303	-1.0291	-1.0218	-1.03e+00	-1.03e+00	-1.03e+00	-1.03e+00
F17	0.4018	3.98e-01	0.4050	4.07e-01	4.05e-01	4.04e-01	4.09e-01
F18	3.0247	3.0356	3.2756	3.05e+00	3.00e+00	3.01e+00	3.07e+00
F19	-3.86e+00	-3.86e+00	-3.8476	-3.86e+00	-3.85e+00	-3.86e+00	-3.86e+00
F20	-3.0550	-3.3129	-3.16e+00	-3.30e+00	-3.17e+00	-3.19e+00	-3.30e+00
F21	-2.23e+00	-2.6173	-7.2650	-9.74e+00	-4.89e+00	-9.67e+00	-9.86e+00
F22	-7.41e+00	-2.7576	-7.1746	-9.84e+00	-6.16e+00	-9.71e+00	-1.03e+01
F23	-5.2063	-8.47e+00	-6.7634	-1.00e+01	-6.22e+00	-9.87e+00	-5.40e+00

## 4.1 Parametric tests

### 4.1.1 Normality test

The analysis of normality will be completed by the Kolmogorov-Smirnov test. The result is a p-value which represents the dissimilarity of the results with the normal law. The results are given in table 3 with a significance level  $\alpha = 0.05$ .

Table 3: Kolmogorov-Smirnov's normality test

Algorithm	Statistics	p-value
AGWO	0.5205	2.5313e-06
EGWO	0.5205	2.5251e-06
GWO	0.5070	5.2774e-06
IGWO	0.4729	3.0392e-05
MGWO	0.4769	2.4965e-05
COGWO	0.4770	2.4911e-05
EXGWO	0.5207	2.5069e-06

From the table, all the obtained p-values are less than the level of significance  $\alpha$  leading to the rejection of the null hypothesis and therefore the obtained results are not normally distributed.

### 4.1.2 Heteroscedasticity test

This test indicates the presence of a violation of the hypothesis of equality of variances. Levene's test is used to check whether or not homogeneity of variance (homoscedasticity) between the considered 23 samples. Results of the test are shown in figure 6:





values. For the remaining values, the null hypothesis can be rejected at other significances like 1% or 3%. This result leads us to conclude that there is a significant difference between the paired algorithms.

The major disadvantage of this test is that it is not possible to extract a conclusion from more than one pair comparison this is due to the fact that the p-values are independent and we are trying to extract a statistical significance from them. A multiple comparison test should be used to compare more than two algorithms.

#### 4.2.2 Friedman test multiple comparison

The Friedman test is applied to rank multiple algorithms to specify whether there exist significant differences between the results given by the proposed algorithms [18].

Table 5. Mean rank Friedman's test

Algorithm	Friedman's test
AGWO	5.4783
EGWO	4.7391
GWO	4.2826
IGWO	2.9130
COGWO	2.9348
EXGWO	3.4783
MGWO	4.1739
Statistics	2.1332
P-value	1.1953e-04

From table 5, the calculated p-value is less than the significance level  $\alpha$  which means the rejection of the null hypothesis confirming the existence of significant differences between the compared algorithms.

The proposed GWO variants have been highlighted as the two best from the statistical analysis. However, this conclusion has to be validated by another kind of optimization problems which are more complex and has more parameters to be optimized.

## 5 GWO optimization of Inverted Pendulum controllers

We aim to find the optimal parameters of the considered controllers using the proposed GWO variants to ensure that the inverted pendulum follows the desired reference  $\theta_d = 0$ . To do that, we propose the flowchart given in figure 7:

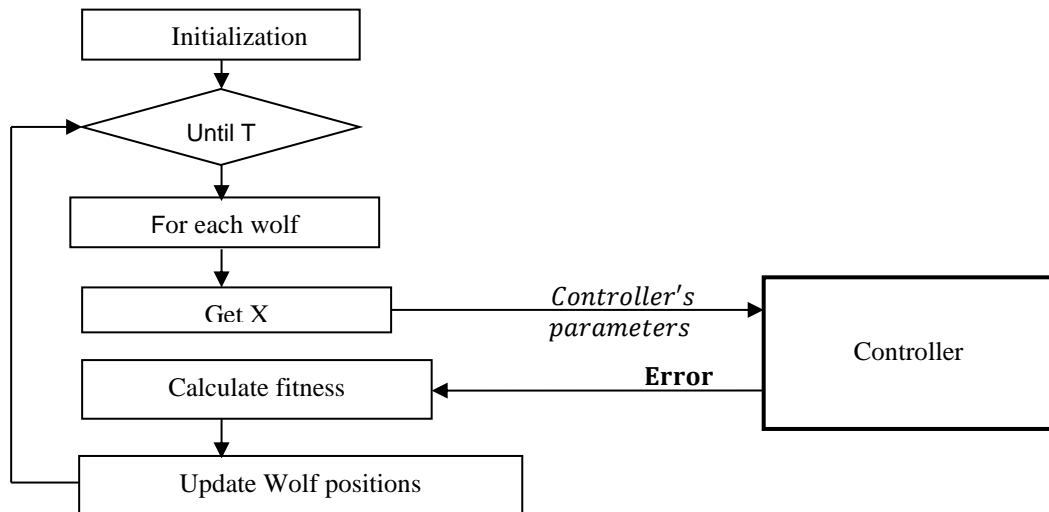

Figure 7. GWO for a controller optimization

The objective function is a mean of squared-error (MSE) calculated by equation:

$$\text{Fit} = \frac{1}{n} \sum_{t=1}^n e(t)^2 \quad (21)$$

For the PID controller, each wolf is a three-dimensional vector composed of  $k_p$ ,  $k_i$  and  $k_d$  :

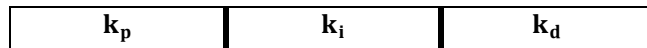

Figure 8. Structure of the PID's wolf.

In the case of FSMC controller, the number of parameters to be tuned is large which increase the dimensions of the search space to  $\text{dim}=20$  (see figure 9). The structure of a wolf will contain the definition of 9 membership functions (3 for each input/output), a multiplying gain  $mg$ , and the indexes of the fuzzy rules in the range  $[1,9]$ :

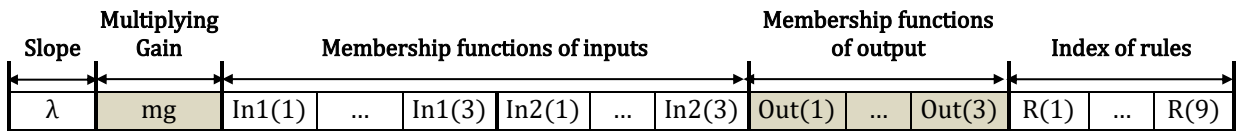

Figure 9. Structure of the FSMC's wolf.

## 6 Experimental results and discussion

To validate the proposed GWO based control structure, we carry out simulations to control a nonlinear inverted pendulum with the following parameters:

$$g = 9.8 \text{ m/s}, mc = 0.57 \text{ kg}, mp = 0.23 \text{ kg}, l = 0.3302 \text{ m}, d(t) = 20 \sin(2\pi t)$$

In the following, we will use our proposed GWO variants (COGWO and EXGWO) which have been selected as the best ones in the statistical comparison to tune the parameters of both the PID controller and the fuzzy sliding mode controller than compare their results to the original GWO algorithm. To ensure a fair comparison, we used same initial population for the three algorithms and the same initial parameters as shown in table 6:

Table 6: Initial parameters of GWO variants.

Parameters	Values
Number of Search Agents (N)	50
Max Number of iterations (T)	50

The first simulation concerns tuning the PID's parameters where  $k_p$ ,  $k_i$  and  $k_d$  gains are in the range  $[1,100]$ .

The fitness of GWO, COGWO and EXGWO algorithms is given in Figure 10 and the position error is given in Figure 11. We note from the first figure that the proposed algorithms have given best results compared to GWO. Indeed, the GWO best fitness value is  $1.341 \times 10^{-3}$  while for the COGWO and EXGWO are respectively  $1.3272 \times 10^{-3}$  and  $1.3277 \times 10^{-3}$ .

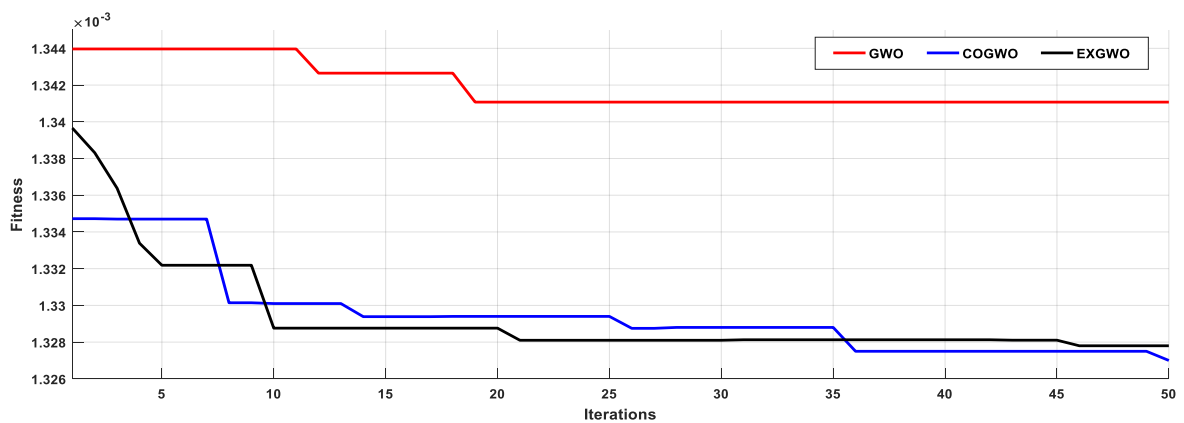

Figure 10. GWO, COGWO and EXGWO fitness values evolution for PID controller

Even the same initial population is used, the COGWO and EXGWO outrun the GWO starting from the first iteration due to the DLH module which contribute to a best exploration in the search space. These performances directly affect the position errors of the three optimized controllers (see figure 10) where the GWO based controller has a great

overshoot value up to 25% from the initial position. The best value is given by the COGWO based controller with a small overshoot less than 10% with a neglected undershoot. The three algorithms obtained a rise time less than 0.02 seconds and they converge towards the steady error equal to  $3.9 \times 10^{-3}$ . The settling time of the COGWO is between [0.06, 0.08].

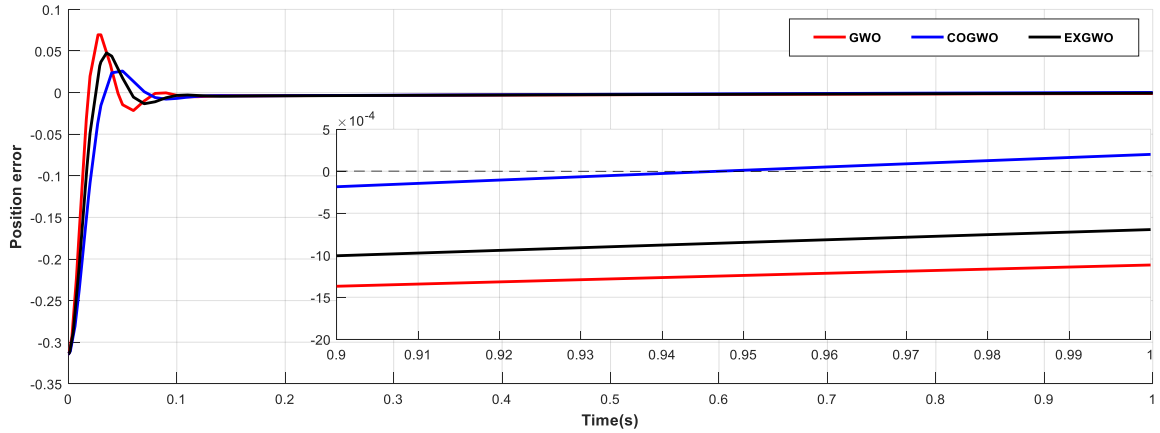

Figure 11. Position error for PID controller using GWO, COGWO and EXGWO algorithms

It is clear that the gains obtained by the COGWO algorithm improve the performance of the controlled system. This algorithm has obtained a reduced rise time and the smallest overshoot compared to the other competitors.

In the second simulation, we aim to tune and optimize the FSMC's controller parameters mentioned in section (2.3). The range of definition of these parameters is presented in table 7. Same initialization is provided for the three algorithms.

Table 7. Range of FSMC's parameters

Parameters	Parameters number	Range
Mg	1	[1,200]
$\lambda$	1	[1,200]
Membership of e and $\dot{e}$	6	[-1,1]
Membership of out	3	[0,1]
Index of rules	9	[1,9]

The fitness evolution and the position error of the three concerned algorithms are depicted respectively in figures 12 and 13.

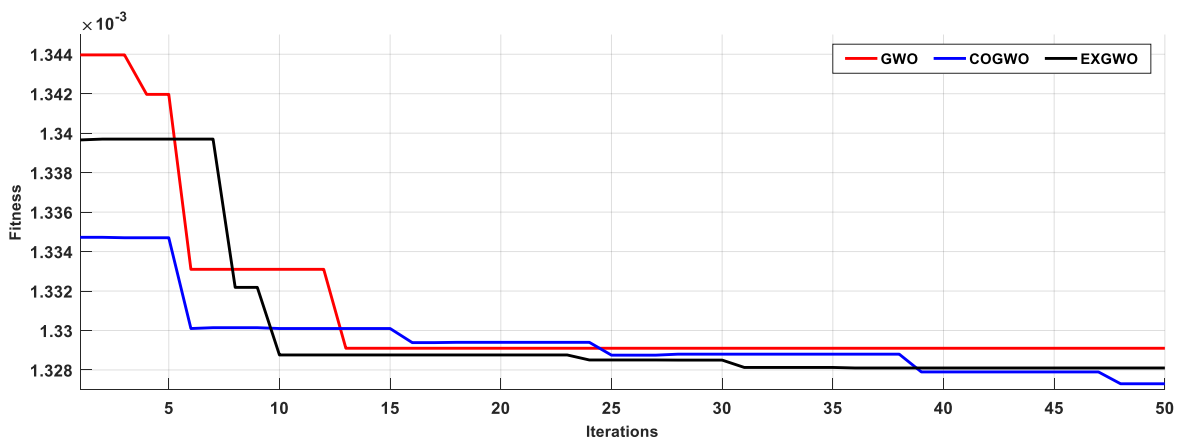

Figure.12. GWO, COGWO and EXGWO fitness values evolution for FSMC controller

According to figure 12, the best results are furnished by the proposed algorithms with minimal fitness values of  $1.3272 \times 10^{-3}$  for COGWO and  $1.328 \times 10^{-3}$  for EXGWO. However, the best fitness value for GWO is  $1.329 \times 10^{-3}$ .

The performance of COGWO and EXGWO outperform GWO which indicate a best exploration of the search space due to the DLH phase involved in these two algorithms.

In term of position error shown in figure 13, all algorithms achieve a rise time less than 0.2 seconds converging to the steady error equal to  $3.2 \times 10^{-4}$ . EXGWO attain the greatest overshoot which is up to 12% from initial position. However, COGWO gave a slight overshoot less than 8% and a neglected undershoot. The settling time of the COGWO algorithm is between [0.21, 0.22].

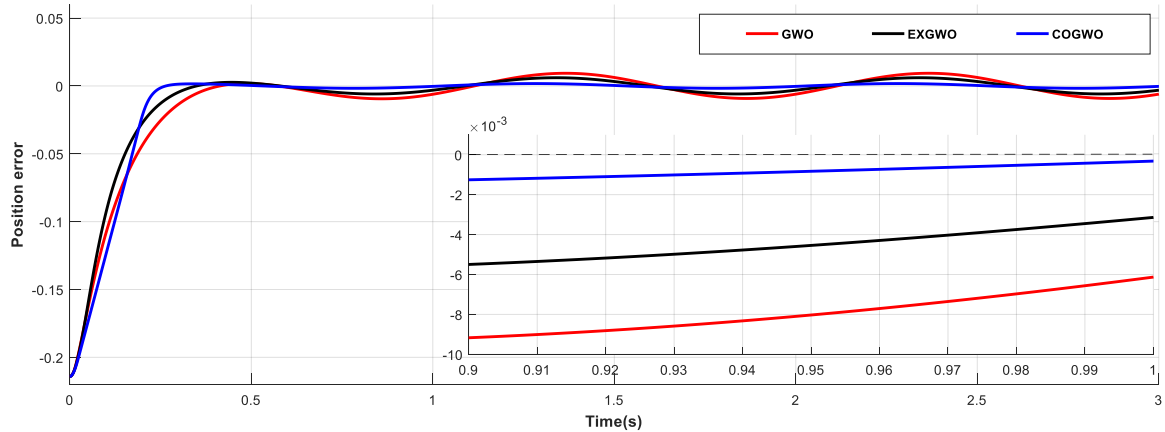

Figure 13. Position error for the FSMC using GWO, COGWO and EXGWO algorithms

From results, the COGWO achieve good results in term of small rise time, the smallest overshoot and it is less unstable then the two other variants where it shows less oscillations in the steady state. This behaviour is caused by the chattering phenomena which is more delayed or cancelled by COGWO compared to EXGWO and GWO. These results could be justified in part by the new control parameter (a) formula. Certainly, as described in section 3, the parameter (A) is responsible for the exploration/exploitation which means that the balance of these processes depends mainly on the behaviour of the control parameter (a) as in equation (4).

The following figure shows the convergence of the control parameter (a) during 50 iterations for GWO, EXGWO and COGWO algorithms.

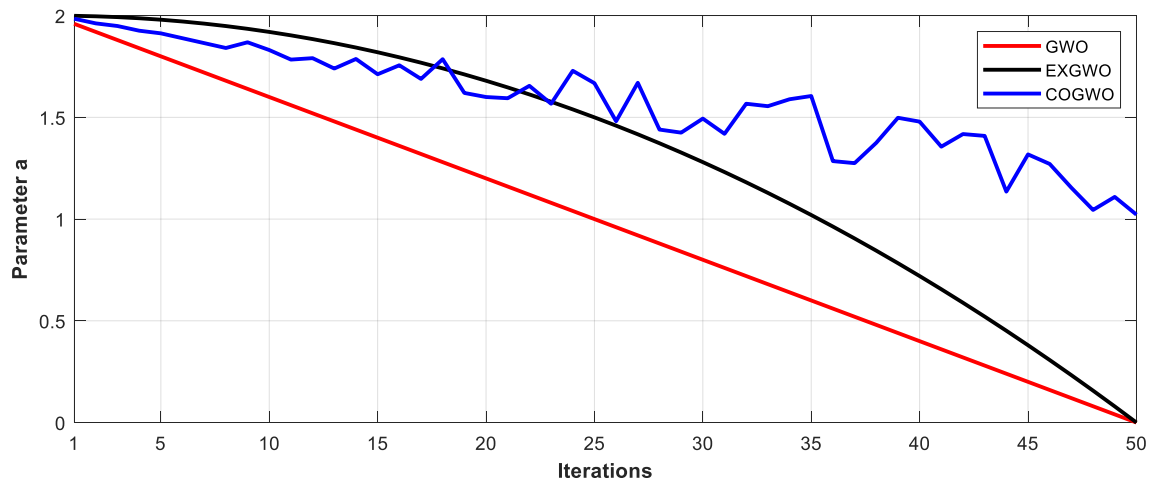

Figure 14. Convergence of the control parameter a.

As can be seen in figure 14, the parameter (a) is decreased from 2 to 0 for GWO and EXGWO algorithms, however, this parameter decreases from 2 to 1 in the COGWO.

In the GWO algorithm, the control factor has a linear decreasing behaviour which leads to a weakness in term of imbalance between exploitation/exploration [18]. To tackle this issue, the EXGWO's factor is based on the exponential decay function which enhances the percentage of iterations used for exploration to approximately 60%

and 40% for exploitation [19]. In COGWO, the control factor decreases using a random based cosine function where the probability of exploration is more than exploitation.

## 7 Conclusion

In this paper, two tuning methods based on Grey Wolf Optimizer (GWO) are proposed to balance the exploration/exploitation ratio and fasten the search process. Two major modifications are applied: the first one concern the use of two formulas for the control parameter ( $a$ ) to enhance the exploitation/exploration process and the second one concerns the movement strategy of wolves where we tried to avoid trapping in local minima by decreasing the dependency to the alpha wolves in the original GWO.

The two proposed variants are highlighted as the two best algorithms from the statistical analysis provided by comparing our proposal (COGWO and EXGWO algorithms) with five other variants of GWO algorithm. The comparison was done with the same initialization for twenty runs. Next, the two enhancements are applied to tune the PID and FSMC controllers used to control the pole angle of a nonlinear inverted pendulum. When compared in the same conditions to the original GWO, our propositions had given best results in term of overshoot, rise and settle time and steady error. The proposed strategy seems to work better.

The proposed approach offers interesting perspectives for both practical applications and research. Indeed, this approach can contribute to advancements in the field of nonlinear and unstable systems. In terms of future work, further investigations can focus on refining the GWO algorithm's parameters and exploring different variations of the approach to enhance its performance and convergence speed. Additionally, this application could be extended to several nonlinear systems as robot, elastic pendulum and artificial pancreas where finding the optimal solutions is crucial for the humans.

## References

- [1] S. Mirjalili, S.M. Mirjalili and A. Lewis. Grey Wolf Optimizer. *Advances in Engineering Software*, 69:46-61,2013. <https://doi.org/10.1016/j.advengsoft.2013.12.007>.
- [2] P. Hu, S. Chen, H. Huang, G. Zhang and L. Liu. Improved Alpha-Guided Grey Wolf Optimizer. In *IEEE Access*, 7:5421-5437, 2019. doi: 10.1109/ACCESS.2018.2889816.
- [3] H. Joshi and A. Sankalap. Enhanced Grey Wolf Optimization Algorithm for Global Optimization. *Fundamenta Informaticae*, 153:235-264, 2017. DOI: 10.3233/FI-2017-1539
- [4] N. Mittal, U. Singh and B.S. Sohi. Modified grey wolf optimizer for global engineering optimization. *Applied Computational Intelligence and Soft Computing*, 2016 : 7950348. <https://doi.org/10.1155/2016/7950348>
- [5] M. Qais, H. Hasanien and S. Alghuwainem. Augmented grey wolf optimizer for grid-connected PMSG-based wind energy conversion systems. In *Applied Soft Computing*, Volume 69:504-515, 2018. <https://doi.org/10.1016/j.asoc.2018.05.006>.
- [6] M. Nadimi-Shahraki, S. Taghian and S. Mirjalili. An improved grey wolf optimizer for solving engineering problems. *Expert Systems with Applications*, 166, 113917, 2021. <https://doi.org/10.1016/j.eswa.2020.113917>.
- [7] G. Xu, Q. Cui, X. Shi, H. Ge, Z. Zhan, H.P. Lee, Y.Liang, R. Tai and C. Wu. Particle swarm optimization based on dimensional learning strategy. *Swarm and Evolutionary Computation*, 45: 33-51, 2019. <https://doi.org/10.1016/j.swevo.2018.12.009>.
- [8] Banerjee R., Dey N., Mondal U. and Hazra B.: Stabilization of Double Link Inverted Pendulum Using LQR. 2018 International Conference on Current Trends towards Converging Technologies (ICCTCT), pages 1-6, 2018. Doi: 10.1109/ICCTCT.2018.8550915.
- [9] A. Sambo, B. Faisal, N. Tahir and A. Babawuro. Optimal control of inverted pendulum on cart system. *Journal of Physics: Conference Series*, 1502: 012024, 2020. Doi:10.1088/1742-6596/1502/1/01202
- [10] Troshina G. V., Voevoda A. and Bobobekov K. : The parameters determination of the inverted pendulum model in the automatic control system. 2016 13th International Scientific-Technical Conference on Actual Problems of Electronics Instrument Engineering (APEIE), pages 180-182, 2016.
- [11] V. S. Bandal and P. N. Madurwar: Performance analysis of shunt active power filter using sliding mode control strategies. In the 12th International Workshop on Variable Structure Systems, 214-219, 2012. doi: 10.1109/VSS.2012.6163504.
- [12] Kasera S., Kumar A. and Prasad L.: Analysis of chattering free improved sliding mode control. 2017 International Conference on Innovations in Information, Embedded and Communication Systems (ICIIECS), pages 1-6, 2017. Doi: 10.1109/ICIIECS.2017.8276105.

- 
- [13] N. Kaur, L. Kaur and S. Cheema. An enhanced version of Harris Hawks Optimization by dimension learning-based hunting for Breast Cancer Detection. *Sci. Rep* 11, 21933, 2021.
- [14] S. García, D. Molina and M. Lozano. A study on the use of non-parametric tests for analyzing the evolutionary algorithms' behaviour: a case study. on the CEC'2005 Special Session on Real Parameter Optimization. *J Heuristics* 15:617–644, 2009. <https://doi.org/10.1007/s10732-008-9080-4>
- [15] S. García, A. Fernández, J. Luengo and F. Herrera. Advanced nonparametric tests for multiple comparisons in the design of experiments in computational intelligence and data mining: Experimental analysis of power. *Information Sciences* 180: 2044–2064, 2010. <https://doi.org/10.1016/j.ins.2009.12.010>
- [16] J. Derrac, S. García, D. Molina and F. Herrera. A practical tutorial on the use of nonparametric statistical tests as a methodology for comparing evolutionary and swarm intelligence algorithms. *Swarm and Evolutionary Computation*, 1:3-18, 2011. <https://doi.org/10.1016/j.swevo.2011.02.002>
- [17] F. Wilcoxon. Individual comparisons by ranking methods. *Biometrics bulletin*, 1:80-83, 1945. <https://doi.org/10.2307/3001968>
- [18] W. Long, J. Jiao, X. Liang and M. Tang. An exploration-enhanced grey wolf optimizer to solve high-dimensional numerical optimization. *Engineering Applications of Artificial Intelligence*. 68: 63-80, 2018. <https://doi.org/10.1016/j.engappai.2017.10.024>.
- [19] S. Li, S. Wang, P. Wang, X. Su, X. Zhang and Z. Dong. An improved grey wolf optimizer algorithm for the inversion of geoelectrical data. 66:607–621, 2018. doi:10.1007/s11600-018-0148-8.
-